

SIZE REDUCTION

LAB SANITARY MILL



Features

- Interchangeable impact, knife, and bar rotors
- Vacuum system to create a negative airflow through the mill
- Front door screen access
- Scalable across the product line
- Quick disconnect drive shaft assembly
- 2-step blade safety access
- Power: 220V single phase

The Lab Sanitary Mill (LSM) is a table top mill designed to process lab test batches with transferable results to full scale production equipment. It provides a range of particle sizes, from an APS of 150 micron to your desired top size. The LSM is ideal for use within the pharmaceutical industry, however, outperforms competition in the industrial and nutraceutical industries as well.

This mill uses “in-air” impact milling, a preferred method as it shatters the material along its natural ‘fracture point,’ achieving the highest first impact yield. This technique minimizes the percentage of material requiring a second impact, maintains a lower temperature, and reduces overall fines generation.

Important to Note:

The LSM is supplied with FDA approved polymers and 316L stainless steel product contact parts designed to fit into an autoclave.



LAB SANITARY MILL

FEATURES

Vacuum System

The sealed design of the LSM requires an integrated vacuum system in order to run at optimum efficiency. The vacuum provides a constant negative airflow within the milling chamber to relieve any positive pressure that would otherwise accumulate as the 1L product container fills. Without a vacuum system, a pressure build up will create negative results, such as finer particle size, increased temperature, and product release from the top of the machine (i.e. “blowback”).

Front Screen Access

IPA’s improved design eliminates any previous hassle of awkward handling. The quick access front door simplifies the process to change the rotor, swap out the screen, and it reduces fines spillage. This design has been frequently requested in years past and has proven to increase efficiency during maintenance and handling.

Scale Up Data

The LSM was designed to smoothly scale up to larger applications. Below is a summary chart comparing the data from the LSM to the IPA M6x15 Mill. In scaling, feed rate, rotor speed, and screen size were proportionately adjusted.

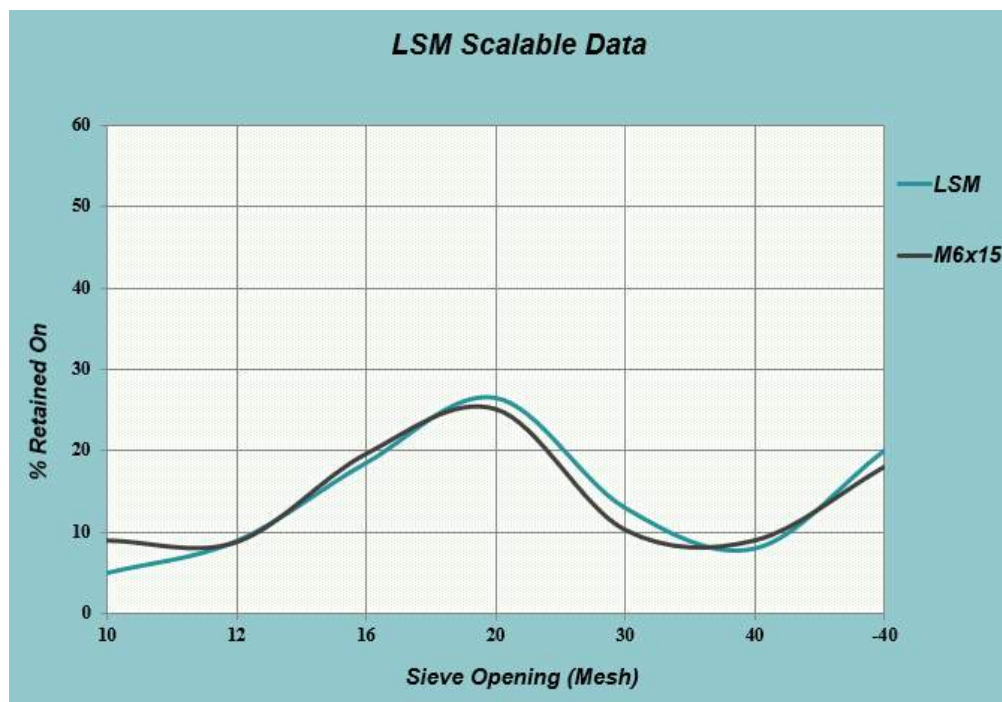

LAB SANITARY MILL

PACKAGE OPTIONS



LSM, Standard Model

- Fully Assembled & Ready to Operate
- 225 Knife/Impact Blade
- Includes 5 Screens
- With Controls

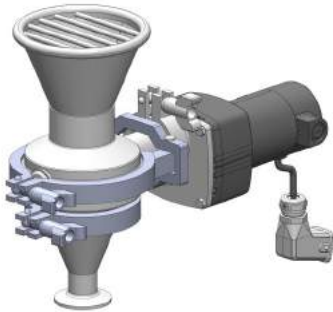

Rotary Valve Feeder

- Eight Pocket Rotor
- Variable Drive, 3-12 RPM
- Directly Plugs into Base

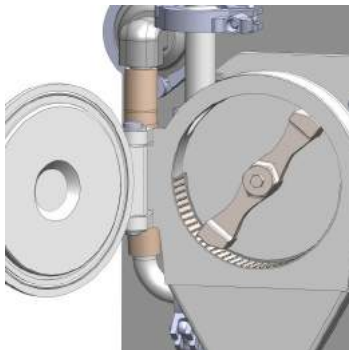

Bar Rotor

- Ideal for Processing Softer Materials
- Two-Bar Rotor
- Provided with Conidur Screens for High Efficiency Milling



Power Supply

- Converts 120V to 220V, single phase
- Required for Labs with 120V Only Power

LAB SANITARY MILL

DIMENSIONS & SPECS

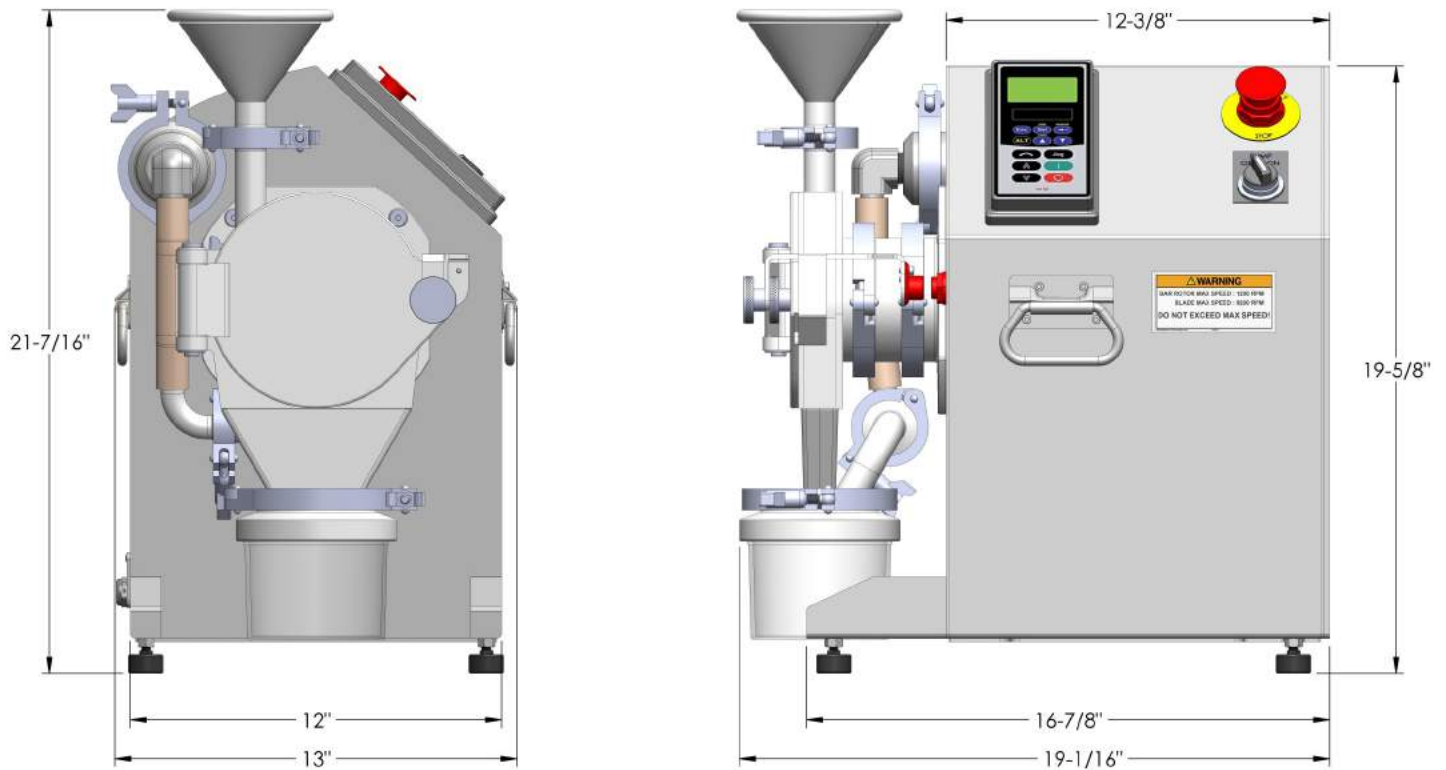

Mill Size	Competitive Model	Rotor Diameter	Mill Speed Ratio	Capacity Range (0.079" - 0.25" RH Screen)	Scale Up Factor	Mill Overall Dimensions (LxWxH)
		inch / cm	Ratio	lbs/hr / kgs/hr	Ratio	inch / cm
LSM	L1A	5.4 in	1.94	28 - 105 lbs/hr	0.07	19x13x22 in
		13.7 cm		13 - 48 kgs/hr		48x33x56 cm
(P)M6X15	D6A / DASO6	10.50	1.0	400 - 1500	1.0	39x30x64
		26.67		180 - 680		100x75x160
M12x15	DKASO12	10.50	1.0	960 - 3600	2.4	42x36x73
		26.67		435 - 1635		105x90x185
M8x22	FASO8	14.375	0.743	720 - 2700	1.8	61x36x63
		36.51		325 - 1225		155x90x160
M12x22	FASO12	14.375	0.743	1120 - 4200	2.8	61x40x63
		36.51		510 - 1910		155x100x160
M20x22	FASO20	14.375	0.743	1960 - 7350	4.9	63x49x85
		36.51		890 - 3340		160x125x215
M30x28	HASO30	17.25	0.609	3600 - 13500	9.0	77x69x70
		43.82		1635 - 6135		195x175x178

